

No.	REVISIONS	DATE	BY
A	RELEASE TO PRODUCTION	MARCH 2008	JAG

I USED A $\frac{1}{4}$ SHEET SIZE PALM SANDER TO CLEAN UP MY FRAME RINGS. I STARTED WITH 100 GRIT, THEN 125 AND FINISHED WITH 150 GRIT. THAT GAVE ME A NICE FINISH TO LEAVE AS IS, OR TO PAINT.

I USED A 82° SINGLE FLUTE COUNTERSINK BIT. SINGLE FLUTE ON THIS SOFT ALUMINUM LEAVES A NICE COUNTERSINK

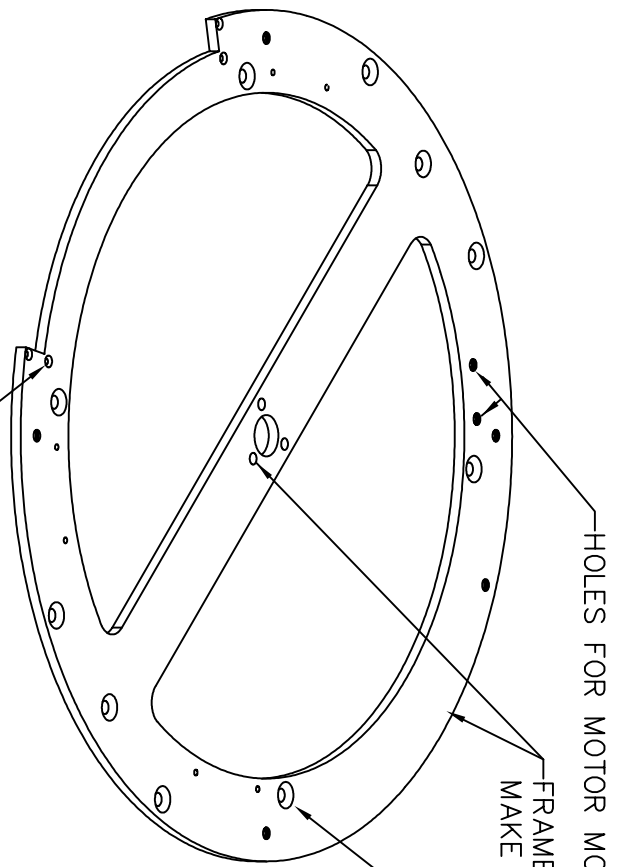

10-COUNTERSINK HOLES
82° x Ø0.562 CSINK

4-COUNTERSINK HOLES
82° x Ø0.250 CSINK

UNLESS OTHERWISE SPECIFIED DIMENSIONS ARE IN INCHES (MM)	
XX	ANGLES
±.015	±1/2°
MATERIAL ALUM ALLOY	
6061-T6	
FORMAT	

 FRAME RING #1	
R2-D2 BUILDERS CLUB DRAWING NO. JAG V5.0	REV. A
SCALE: FULL DRAWN: MARCH 2008 SHEET: 1 OF 1	

No.	REVISIONS	DATE	BY
A	RELEASE TO PRODUCTION	MARCH 2008	JAG

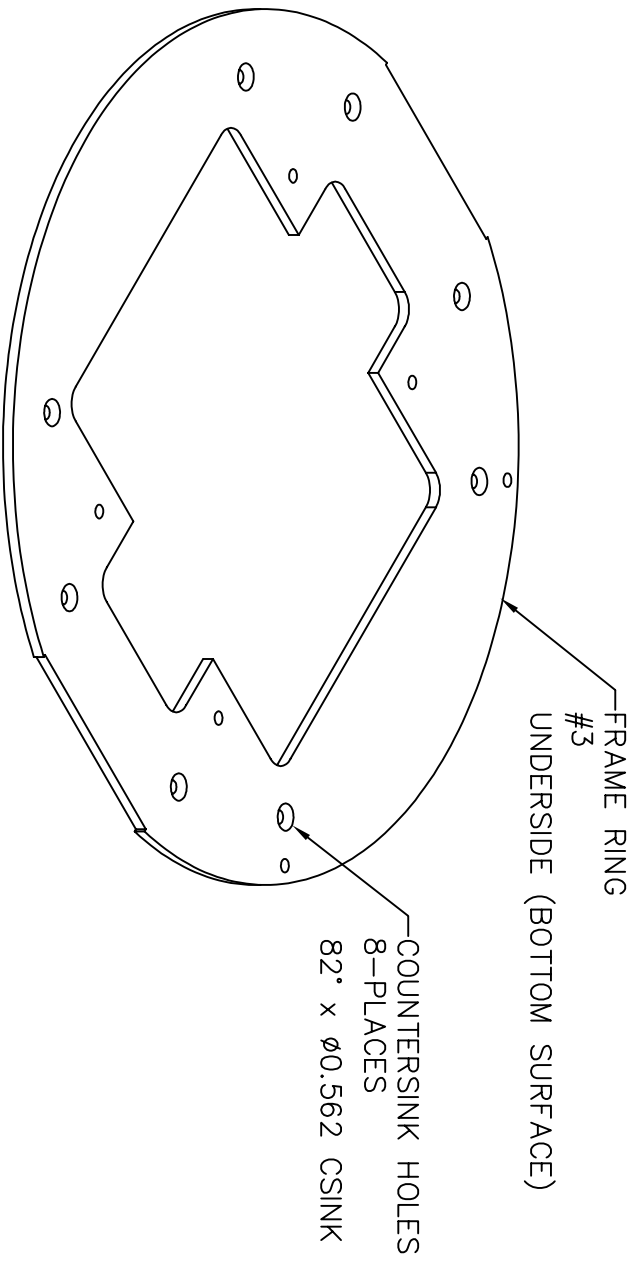

UNLESS OTHERWISE SPECIFIED DIMENSIONS ARE IN INCHES (MM) TOLERANCES ARE:		DRAWING NO.		REV.	
.XX	.XXX	R2-D2 BUILDERS CLUB		A	
±.015	±.005	DRAWING NO.		A	
MATERIAL		DRAWING NO.		A	
ALUM ALLOY		JAG V5.0		A	
6061-T6		SCALE: FULL		SHEET: 1 OF 1	
		DRAWN: MARCH 2008			
		DATE			
		BY			
		MARCH 2008			
		JAG			

FRAME RING
#3

No.	REVISIONS	DATE	BY
A	RELEASE TO PRODUCTION	MARCH 2008	JAG

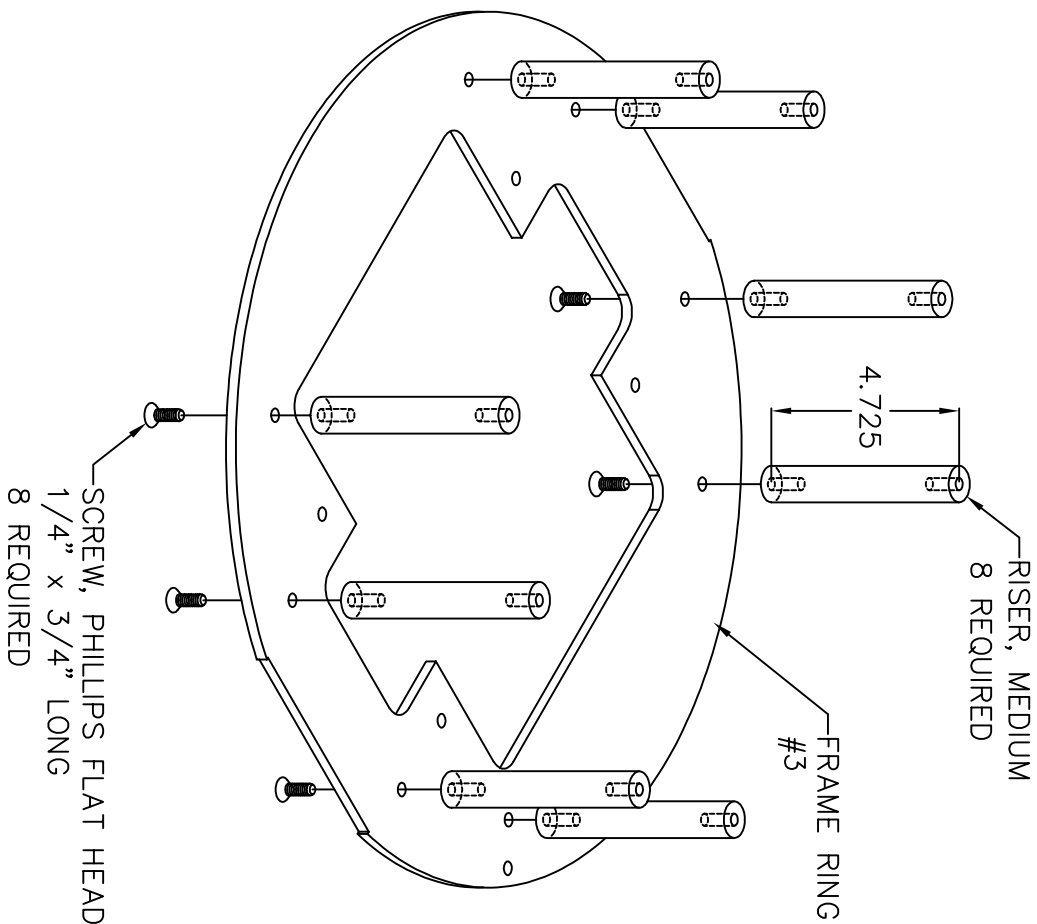

UNLESS OTHERWISE SPECIFIED
DIMENSIONS ARE IN INCHES (MM)
TOLERANCES ARE:
.XX .XXX ANGLES
±.015 ±.005 ±1/2°

MATERIAL
ALUM ALLOY
6061-T6

FR2-D2 BUILDERS CLUB
DRAWING NO.
JAG V5.0

SCALE: FULL DRAWN: MARCH 2008 SHEET: 1 OF 1

FRAME ASSY
PAGE 1

REV: A

No.	REVISIONS	DATE	BY
A	RELEASE TO PRODUCTION	MARCH 2008	JAG

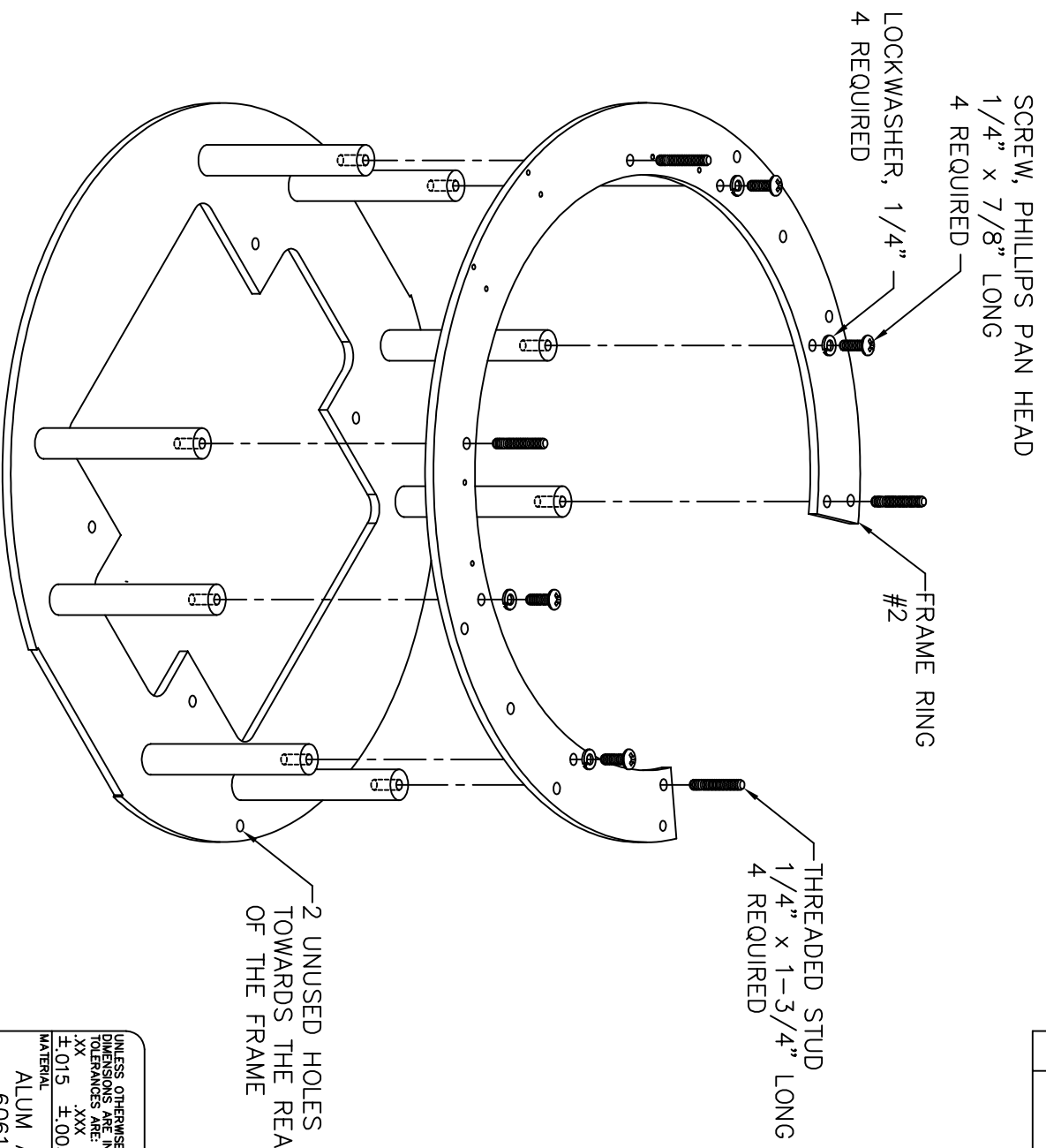

UNLESS OTHERWISE SPECIFIED
DIMENSIONS ARE IN INCHES (MM)
TOLERANCES ARE:
.XX .XXX ANGLES
±.015 ±.005 ±1/2°

MATERIAL
ALUM ALLOY
6061-T6

FORMAT

FRAMES CLUB
PAGE 2

82-02 BUILDERS CLUB
DRAWING NO.
JAG V5.0

SCALE: FULL
DRAWN: MARCH 2008
SHEET: 1 OF 1
REV: A

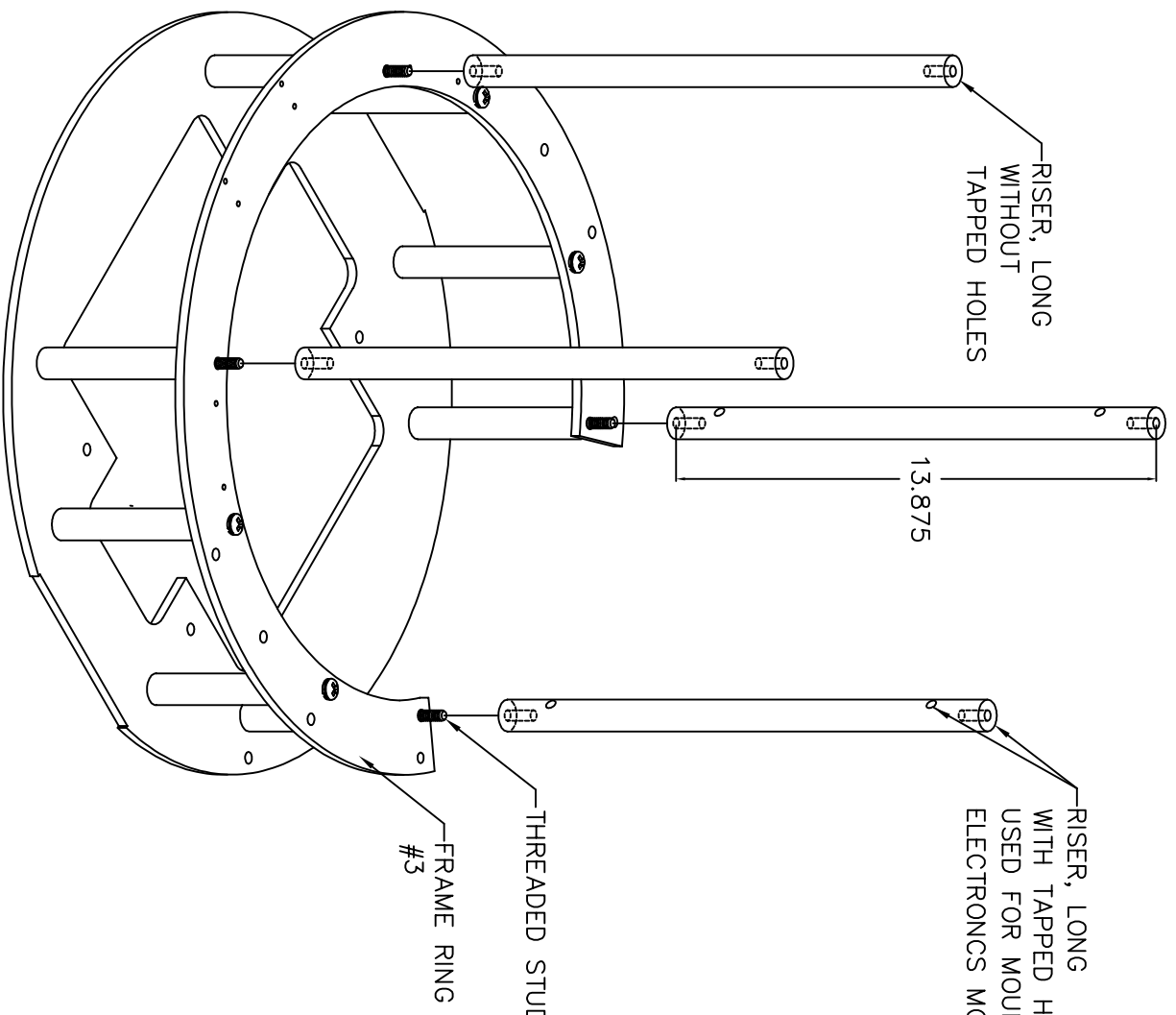

No.	REVISIONS	DATE	BY
A	RELEASE TO PRODUCTION	MARCH 2008	JAG

UNLESS OTHERWISE SPECIFIED
DIMENSIONS ARE IN INCHES (MM)
TOLERANCES ARE:
.XX .XXX ANGLES
±.015 ±.005 ±1/2°

MATERIAL
ALUM ALLOY
6061-T6

82-02 BUILDERS CLUB
DRAWING NO.
JAG V5.0

SCALE: FULL DRAWN: MARCH 2008 SHEET: 1 OF 1

FRAME ASSY
PAGE 3

REV: A

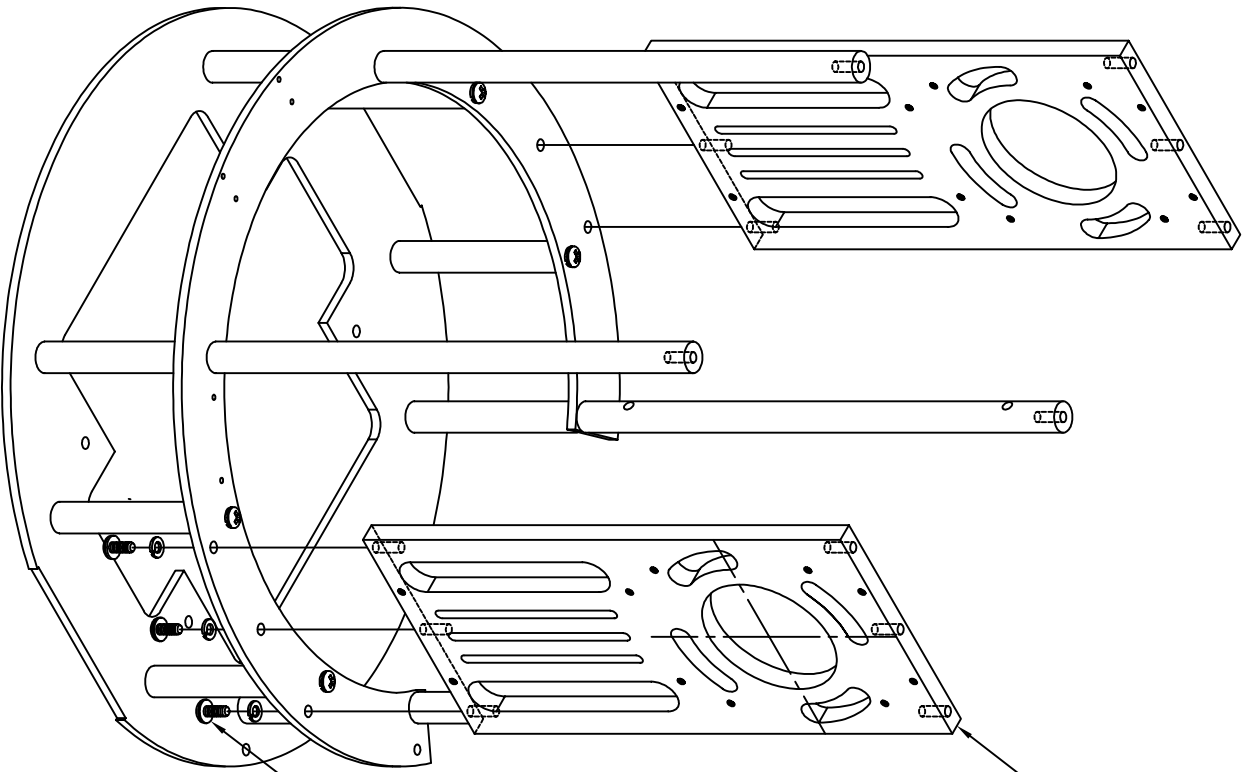

SHOULDER MOUNTING
PLATE

SCREW, PHILLIPS PAN HEAD
1/4" x 7/8" LONG
6 REQUIRED

No.	REVISIONS	DATE	BY
A	RELEASE TO PRODUCTION	MARCH 2008	JAG

UNLESS OTHERWISE SPECIFIED DIMENSIONS ARE IN INCHES (MM) TOLERANCES ARE:		ANGLES	
.XX	.XXX	± 1/2°	
±.015	±.005		
MATERIAL			
ALUM ALLOY			
6061-T6			
FORMAT			
R2-D2 BUILDERS CLUB		FRAME ASSY	
DRAWING NO.		PAGE 4	
JAG V5.0			
SCALE: FULL	DRAWN: MARCH 2008	SHEET: 1 OF 1	REV: A

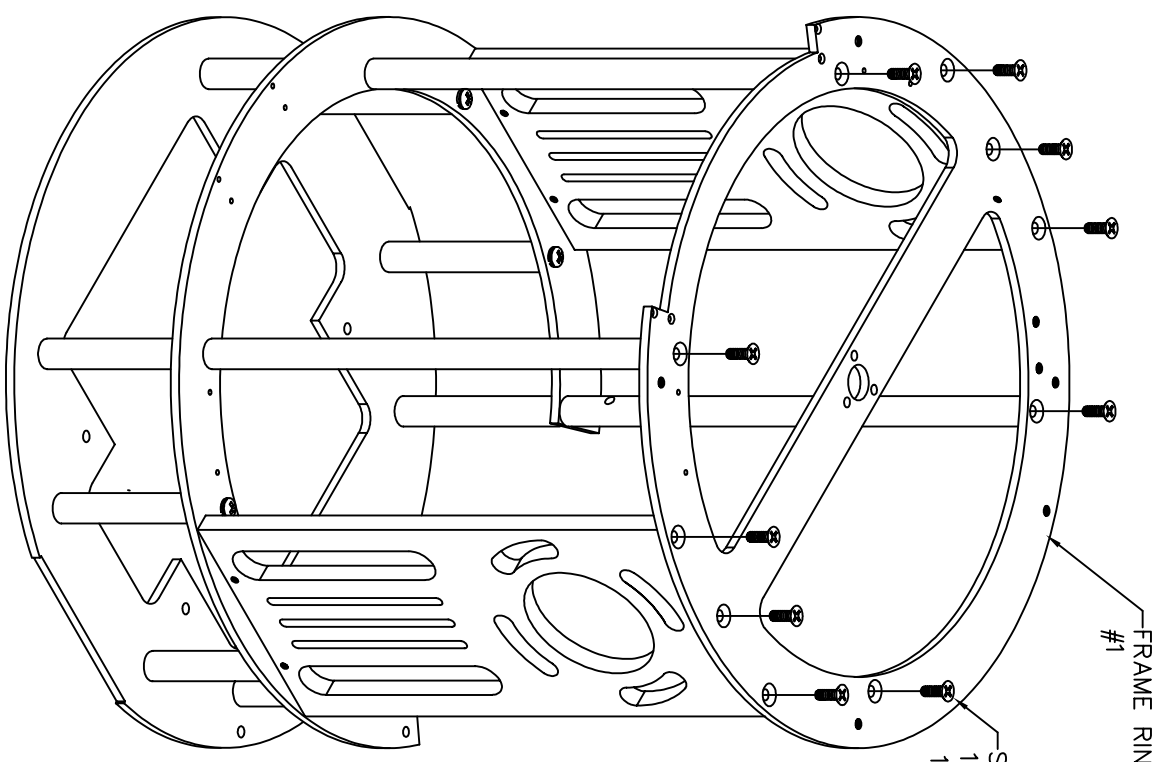

No.	REVISIONS	DATE	BY
A	RELEASE TO PRODUCTION	MARCH 2008	JAG

SCREW, PHILLIPS FLAT HEAD
1/4" x 3/4" LONG
10 REQUIRED

#1
FRAME RING

UNLESS OTHERWISE SPECIFIED DIMENSIONS ARE IN INCHES (MM)	
TOLERANCES ARE:	ANGLES
.XX	.XXX
±.015	±.005 ±1/2°
MATERIAL	
ALUM ALLOY	
6061-T6	
FORMAT	

R2-D2 BUILDERS CLUB	
DRAWING NO. JAG V5.0	
SCALE: FULL	
DRAWN: MARCH 2008	
SHEET: 1 OF 1	
FRAME ASSY	
PAGE 5	
REV. A	